

MAXIMIZER

Gas Pizza Ovens

MODEL CW61P

General Features:

- Quality Construction for long life
- Stainless Steel Front Standard
- Large Capacity
2,688 sq. inches of available cooking space. Holds eight (8) 16" pizzas
- Pizza Decks Standard
Large 42"x32"x7" compartment
1" pizza stones
- Unique Interior Design
Better distribution of heat
- **Energy Efficient**
New energy-saving "Power-Pak" burner system for even heat and better baking (see inset illustration)
- Full Range Thermostat
300°F - 650°F (149°C - 343°C)
- Space Saver
Only 50" wide
- Stackable
Double cooking capacity
- Easily Serviceable
All controls can be replaced from the front of the unit
- Power
Gas - LP or NAT
- **Specific Features**
of the CW61P listed on the back

Warranty:

- One year parts and labor



**GAS
FIRED**



Hearth
Baffle
Burner

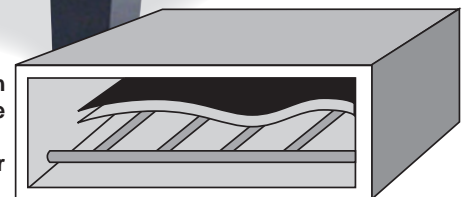

"Power-Pak" 4-Cell Burner System

MORE FOR LESS

More Cooking Space per Floor Space
More Cooking Capacity per Sales Dollar
More Performance per Gas Dollar

 **Peerless**
Commercial and Industrial Ovens

P.O. Box 859 • Sandusky, Ohio 44870 • (419) 625-4514 • FAX 625-4597

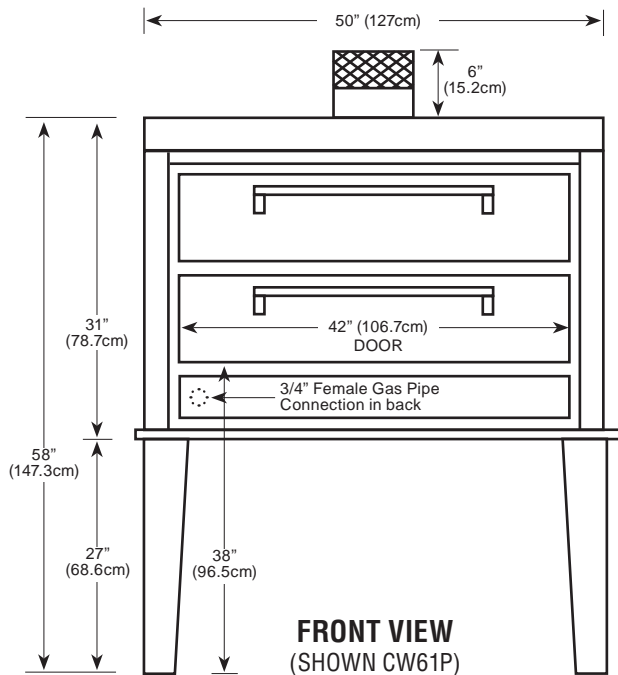
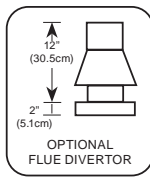

FRONT VIEW
(SHOWN CW61P)

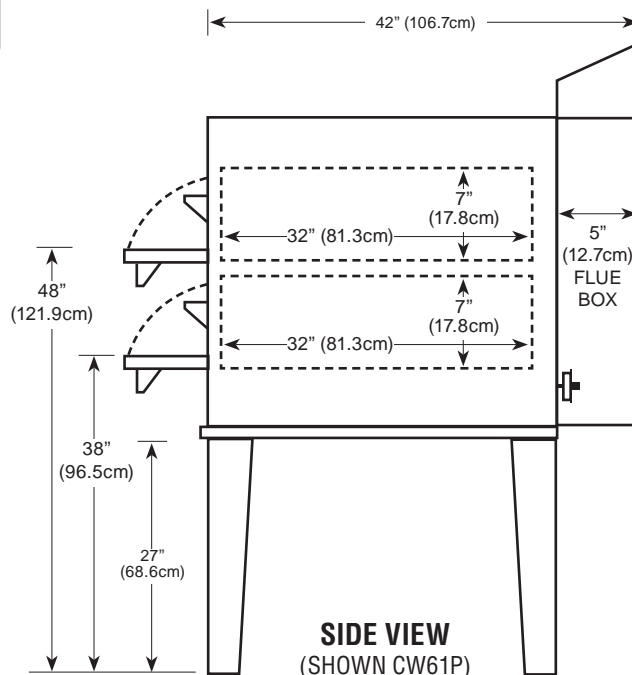

SIDE VIEW
(SHOWN CW61P)

Floor space50" (127cm) wide x 42" (105cm) deep* x 58" (147.3cm) high
Shelf size 42" (106.7cm) wide x 32" (81.3cm) deep x 7" (17.8cm) high
Shipping weight 850 lbs (385.6kg)
Capacity for CW61P Twelve 12" (30.5cm) pizzas or eight 16" (40.7cm) pizzas
Gas 60,000 BTU
Opening required for installation:	32" * Handle adds 2.5"(6.4cm) to depth

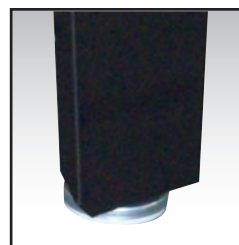

Adjustable Legs

Durable Construction

The CW61P is built with *prime 20-gauge cold-rolled top and sides* with a 14-gauge base. The *interior is made of Armo Type 1, 20-gauge aluminized steel*. The CW61P comes standard with a stainless steel front made of high quality, 18-gauge stainless steel; the door interior is 18 gauge stainless as well.

Energy Efficiency

The CW61P features our *new energy-saving "Power-Pak" 4-cell burner system* and our *unique baffle system*. These make our ovens highly efficient and eliminate hot spots. The *heavily insulated walls*, coupled with our *special vent system*, reduces heat loss and keep your gas dollars from going up the stack. The CW61P is powered by 60,000 highly efficient BTUs which *increase its efficiency and recovery rate*.

Capacity

The CW61P deck size measures 42"x32"x7" (2) decks in one oven. The top deck cooks almost as fast - and as well - as the bottom, providing outstanding capacity for your money. Actual cooking capacity depends on the size of the pizza you are cooking. The CW61P will hold twelve (12) 12" pizzas, eight (8) 16" pizzas, or six (6) 18" pizzas. Cooking time will vary according to product, but will average between 8-10 minutes.

Space Saver

Because the controls are under the doors, the CW61P requires *less installation space* than our competition. This enables you to free up valuable kitchen and/or hood space. The actual width needed is mere 50" for *42"x32"x7" (2) decks*, almost a foot less than the competition. The CW61P *can convert into a CW62PSC by stacking**, either initially or after your business grows. This option gives you four 42"x32" decks in only 56" of space. (*will increase width)

Design Plus

The CW61P has the *controls in the lower front for ease of operation and space savings*. This also places the controls in their own *air-conditioned area* so they are not affected by outside influences. In addition, the CW61P is *totally thermocoupled* and allows you to replace individual parts as opposed to throwing away the whole system.



P.O. Box 859 • Sandusky, Ohio 44870 • (419) 625-4514 • FAX 625-4597